

# LOOP / PSC / EARTH Tester



CE

## 2811 LP

### FEATURES

- Microprocessor-controlled.
- Displays and sound warning if external voltage present.
- Displays mains voltage, scroll trough menus.
- Checks wiring integrity (LEDs and display).
- Single button operation.
- Auto-off/auto-ranging.
- Combined prospective short circuit current, PSC and LOOP tester.
- Built-in carry case, test leads in separate pouch.
- Loop test for L-E and L-N and PSC.
- Voltage test L-N and L-E.
- Enables analysis of constituent components in L-E and L-N loops giving resistance of earth, neutral wire, live wire and transformer winding.
- Display can be customized for special orders.
- 60Hz available on request.



ISL-2811

BET-2800

### SPECIFICATIONS

Loop impedance range L-E, L-N	20/200/2000Ω (auto-range)
Loop impedance test current	12A at 230V / 50Hz
Voltage measurement L-N, L-E	80 to 250V AC/50Hz
Earth wire/path return resistance	20/200/2000Ω (auto-range)
Neutral wire return resistance	20/200/2000Ω (auto-range)
Line wire return resistance & transformer windings	20/200/2000Ω (auto-range)
PSC current (L-N) max	3kA
Operating voltage	230V±20% / Hz
<b>Typical Accuracy</b>	
Loop impedance	±5%rdg ± 2dgt
PSC current	±20%rdg ± 5dgt
Voltage	±1%rdg ± 1dgt
Operating-temperature -humidity	-10°C to +40°C 80% Max. relative humidity
Dimensions	170(L) x 120(W) x 95(D)mm
Weight (battery included)	Approx. 780g
Power source	1.5V (AA) x 8
Safety standard	EN 61010-1 CAT III 250V EN 61326-1 Instruction manual
Accessories	Test leads Shoulder belt Batteries

### FAULT FINDING AND ANALYZING THE ELECTRICAL NETWORK

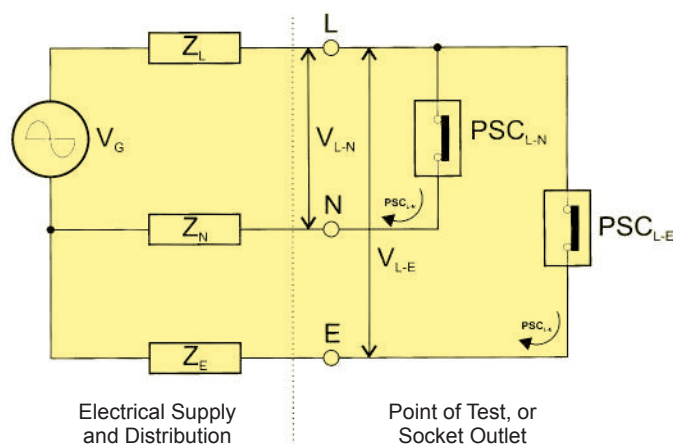

Electrical Supply and Distribution

Point of Test, or Socket Outlet